

10 11 12 13 14 15 16 17 18 19 20

21 22 23 24 25 26 27 28 29 30



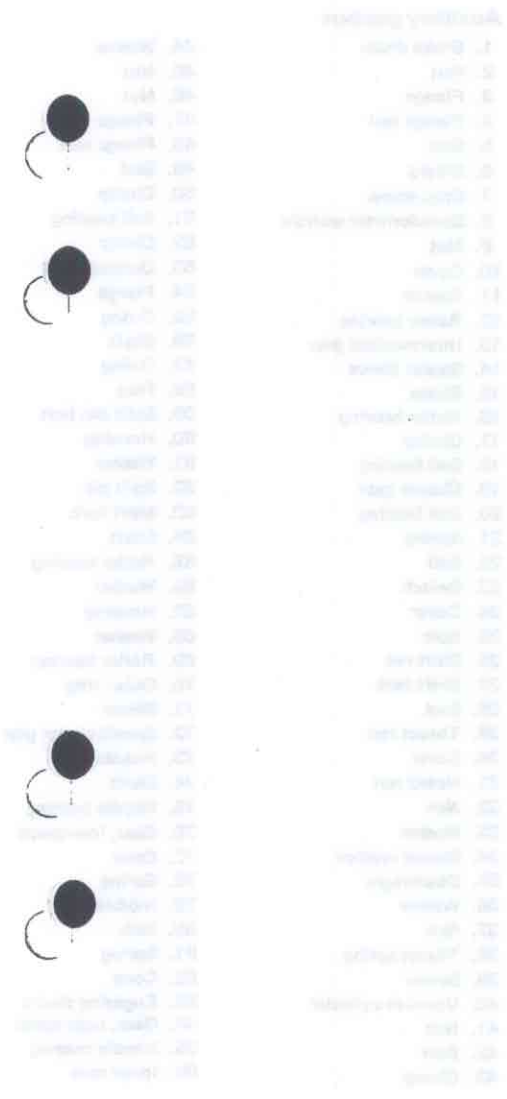
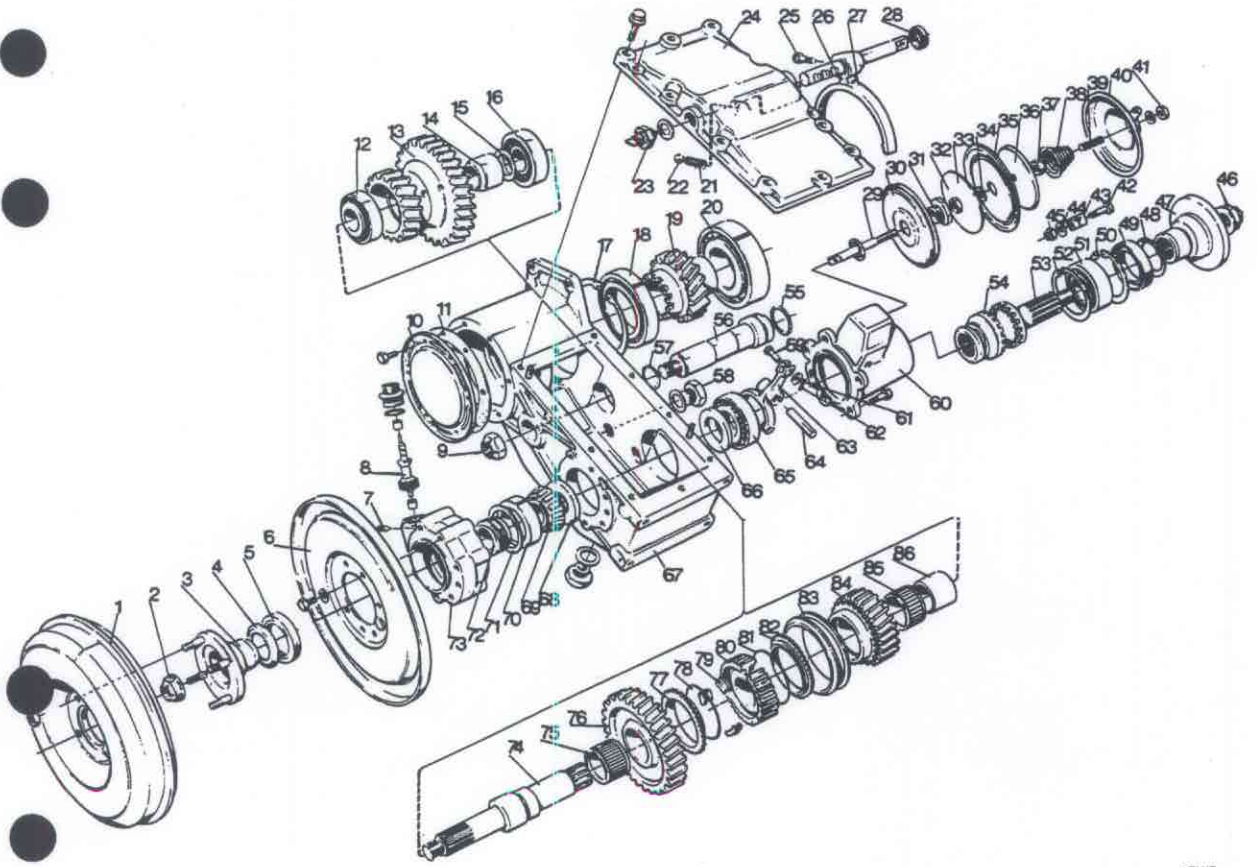

Illustration 43-E. Auxiliary gearbox

Auxiliary gearbox

- | | |
|------------------------|----------------------|
| 1. Brake drum | 44. Washer |
| 2. Nut | 45. Nut |
| 3. Flange | 46. Nut |
| 4. Flange seal | 47. Flange |
| 5. Seal | 48. Flange seal |
| 6. Shield | 49. Seal |
| 7. Stop screw | 50. Circlip |
| 8. Speedometer spindle | 51. Ball bearing |
| 9. Nut | 52. Circlip |
| 10. Cover | 53. Output shaft |
| 11. Gasket | 54. Flange |
| 12. Roller bearing | 55. O-ring |
| 13. Intermediate gear | 56. Shaft |
| 14. Spacer sleeve | 57. O-ring |
| 15. Shims | 58. Plug |
| 16. Roller bearing | 59. Split pin bolt |
| 17. Circlip | 60. Housing |
| 18. Ball bearing | 61. Washer |
| 19. Cluster gear | 62. Split pin |
| 20. Ball bearing | 63. Shift fork |
| 21. Spring | 64. Shaft |
| 22. Ball | 65. Roller bearing |
| 23. Switch | 66. Washer |
| 24. Cover | 67. Housing |
| 25. Bolt | 68. Washer |
| 26. Shift rail | 69. Roller bearing |
| 27. Shift fork | 70. Outer ring |
| 28. Seal | 71. Shims |
| 29. Thrust rod | 72. Speedometer gear |
| 30. Cover | 73. Housing |
| 31. Holed nut | 74. Shaft |
| 32. Nut | 75. Needle bearing |
| 33. Washer | 76. Gear, low-speed |
| 34. Spacer washer | 77. Cone |
| 35. Diaphragm | 78. Spring |
| 36. Washer | 79. Inhibitor |
| 37. Nut | 80. Hub |
| 38. Thrust spring | 81. Spring |
| 39. Screw | 82. Cone |
| 40. Vacuum cylinder | 83. Engaging sleeve |
| 41. Nut | 84. Gear, high-speed |
| 42. Bolt | 85. Needle bearing |
| 43. Clamp | 86. Inner race |



VOLVO
115 987

